

# UT-6408

## 8口百兆非网管型以太网交换机 说明书

### 一、概述

UT-6408是8个端口的百兆非网管型以太网交换机，提供直流输入正反接保护防止烧坏仪器，UT-6408外观设计精巧，同时支持工业标准的卡扣式安装和墙式安装，所以它非常容易安装应用在任何工业网络上。

### 二、主要特性

#### 标准:

IEEE 802.3 10Base-T

IEEE 802.3u 100Base-T(X)

#### 接口:

RJ45端口: 8个10/100Base-T (X) 端口, 自动侦测, 全/半双工MDI/MDI-X自适应

#### LED指示灯:

PWR电源灯, 端口1~8的RJ-45指示灯

#### 电源需求:

输入电压: 12/24/48VDC(10.8~52.8VDC)

功耗: 150mA@24Vmax

接口端子: 1个可插拔的3针接线端子

过载保护: 提供

反接保护: 提供

#### 机械特性:

外壳: IP40防护等级

安装方式: 导轨式安装\墙式安装

尺寸(W x H x D): 150mm 37mm 100mm

#### 工作环境:

工作温度: -20℃ ~ 75℃

储存温度: -40℃ ~ 85℃

相对湿度: 0 ~ 95% (无凝露)

#### 行业标准:

EMI: FCC Part 15 Subpart B class A, EN55022 class A

#### EMS:

IEC(EN)61000-4-2(ESD)

IEC(EN)61000-4-3(RS)

IEC(EN)61000-4-4(EFT)

IEC(EN)61000-4-5(Surge)

IEC(EN)61000-4-6(CS)

IEC(EN)61000-4-8

IEC 60068-2-27(Shock)

IEC 60068-2-32(Freefall)

IEC 60068-2-6(Vibration)

### 三、指示灯

a. PWR: 如图1所示接入直流12/24/48VDC(10.8~52.8VDC)

电源, 电源指示灯PWR亮, 正常工作。

b. RJ-45灯: 接入网线后, 左边绿色灯接100 Base网路亮, 接

10 Base网路不亮; 右边黄色指示灯是网络连接指示灯, 接入

网线正常工作后, 黄色指示灯闪烁。不接网线, 黄绿灯都不

亮。

### 四、连接电源

UT-6408以太网交换机支持直流12/24/48VDC(10.8~52.8VDC)

输入, 还有正反接保护防止烧坏仪器。

1. 在接线盒连接端V+和V-处接入正负极

2. 锁紧螺丝防止DC线松动导致接触不良。



图1 电源输入接口

### 五、外形规格

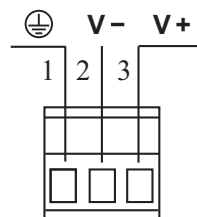
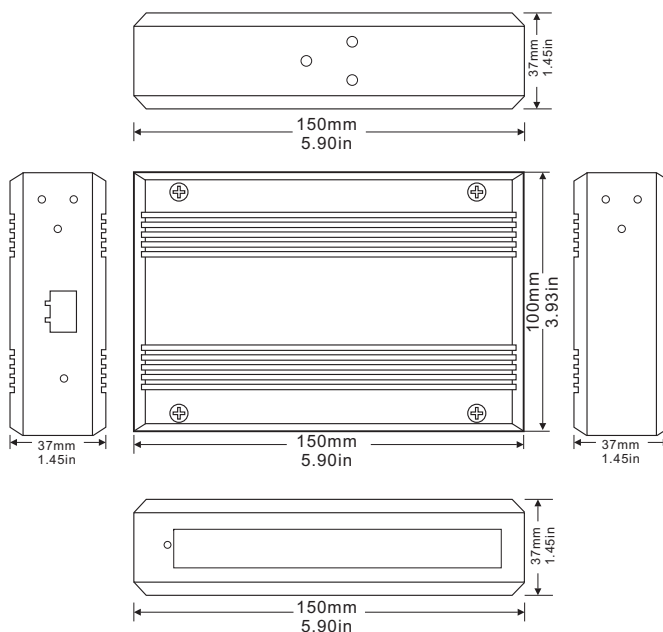

### 六、安装

#### 1、导轨安装

① 将交换机导轨座的上端扣入固定轨道。

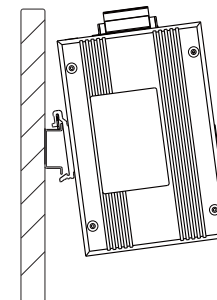

② 再轻轻扣入轨道

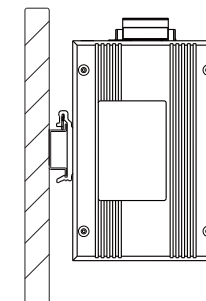

#### 2、墙式安装

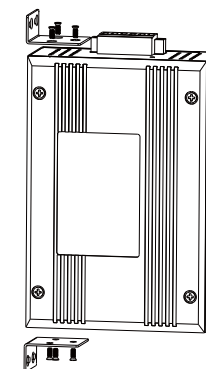

① 使用随机附送的金属固定条按上图扭紧螺丝。

② 再装上锁好金属条的机器悬挂于墙或机柜上。

# UT-6408

## 8-Port 100M Unmanaged Ethernet switch

### User Manual

#### I. Overview

UT-6408 is a 8-port 100M Non-managed Ethernet switch with reverse polarity protection of DC input for avoiding being damaged. It has ingenious appearance design and supports industrial standard DIN-Rail and wall-mounted installation, so it's very easy to be installed and used in any industrial networks.

#### II. Main Features

##### Standard:

IEEE 802.3 10Base-T

IEEE 802.3u 100Base-T(X)

##### Interface:

RJ45 port: 8 10/100Base-T(X) ports, auto detection, full/half-duplex, auto MDI/MDI-X

LED indication:

PWR indicator and RJ-45 indicators for port 1-8

##### Power Supply:

Input Voltage: 12/24/48VDC(10.8~52.8VDC)

Power consumption: 150mA@24Vmax

One pluggable 3-pin terminal block

Overload protection: Yes

Polarity protection: Yes

##### Mechanical Property:

Enclosure: IP40

Method of installation: DIN-Rail/wall-mounted

Dimension (W H D): 150mm 37mm 100mm

##### Working Environment:

Working temperature: -20°C~ 75°C

Storage temperature: -40°C~ 85°C

Relative humidity: 0% ~ 95% (no condensation)

##### Industry Standard:

EMI: FCC Part 15 Subpart B class A, EN55022 class A

##### EMS:

IEC(EN)61000-4-2(ESD)

IEC(EN)61000-4-3(RS)

IEC(EN)61000-4-4(EFT)

IEC(EN)61000-4-5(Surge)

IEC(EN)61000-4-6(CS)

IEC(EN)61000-4-8

IEC 60068-2-27(Shock)

IEC 60068-2-32(Freefall)

IEC 60068-2-6(Vibration)

#### III. Indication Light

a. PWR: 12/24/48VDC(10.8~52.8VDC) power supply connected as shown in figure 1 and the power indication light PWR will light, the switch operates normally.

b. RJ-45: After network cable is connected the left green light will light for 100Base network and not light for 10Base network; The right yellow indication light is network link indication light and it will light when the network cable is connected and switch operates normally. Both yellow and green lights will not light if the network cable is not connected.

#### IV. Power supply connection

UT-6408 Ethernet switch supports 12/24/48VDC(10.8~52.8VDC) power supply inputs, and the DC model equips with reverse polarity protection for avoiding being damaged.

1. Connect the positive/negative polarity to V+ and V- terminals respectively.
2. Tighten the screws to avoid loose connection and bad contact.

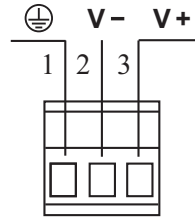
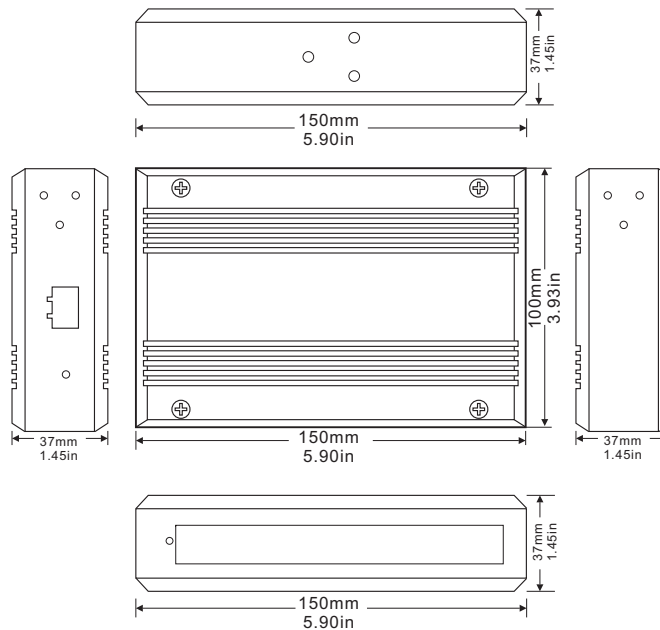

Figure 1 Power supply input terminal

#### V. Dimension



#### VI. Installation

##### 1. DIN-Rail

- ① Push the top of the device rail to fixed rail.

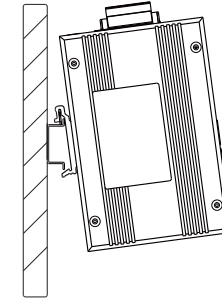

- ② Then push it into the rail slightly again

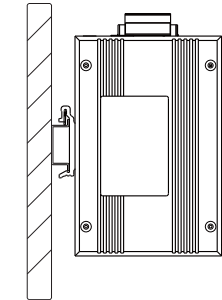

##### 2. Wall-mounted

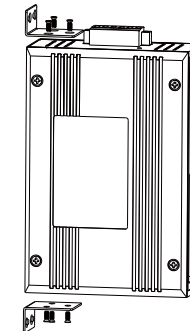

- ① Tighten the metal fixation strip with accompanied screws as shown in the above figure.
- ② Then hang the machine with locked metal strip onto wall or machine cabinet.